

# W LED300K-25

Home | Security | Lighting | White Light

W LED300K-25  
LED White Light Illuminator, 25°, Cold White,  
200-240VAC, 120W, Wall Bracket

**Art-Nr. 71743**



## Main Features

**Colour temperature: 5650K to 7000K (cold white)**  
**Beam angle: 25° (horizontal & vertical)**  
**Luminous Flux: 8500Lumen**  
**Integral switching power supply with softstart**  
**Power supply: 200 to 240VAC, 50Hz**  
**Efficiency factor: 97% (cos Phi >0.9)**

**Low self-heating / Vibration-resistant**  
**Extended temperature range components included**  
**Natural-coloured anodized aluminium casing**  
**Protection rating: IP66**  
**Wall and ceiling mounting bracket included**  
**Option: pole mounting bracket**

## Specifications

<b>Lamp type</b>	LED
<b>Colour temperature</b>	5650 ~7000K
<b>Luminous Flux</b>	8500 Lumen
<b>Angle of light source h</b>	25°
<b>Angle of light source v</b>	25°
<b>Scene coverage</b>	175 m
<b>Twilight switch</b>	no
<b>Temperature related switch-off</b>	At >60°C (system temperature). Automatic restart after falling below the limits
<b>Isolation strength</b>	Class I (leakage path =/>4mm)
<b>Efficiency factor</b>	>97% (PSU), Cos Phi: >0,9
<b>Switch-on delay</b>	Softstart
<b>Heating above ambient air temperature</b>	Max. 35°C

## W LED300K-25

(Continuation Specifications)

Connection	2m Mains connection cable with open ends
Power supply unit	integrated
Protection rating	IP66
Mount	Wall mount bracket included
Supply voltage	200 ~240VAC +/-10%, 50Hz
Power consumption	120W
Temperature range (operation)	-30°C ~+50°C
Housing ventilation	Via air vent
Housing	aluminium with plastic cover
Colour	Housing: anodized silver / Clear cover
Dimensions (HxWxD)	see drawing
Weight	3.5kg

### Optional accessories

71722	PM-80	Pole Mount Adapter IR LED-WBSET (80-180mm Pole)
-------	-------	---

# W LED300K-25

Home | Security | Lighting | White Light

## Technical drawing

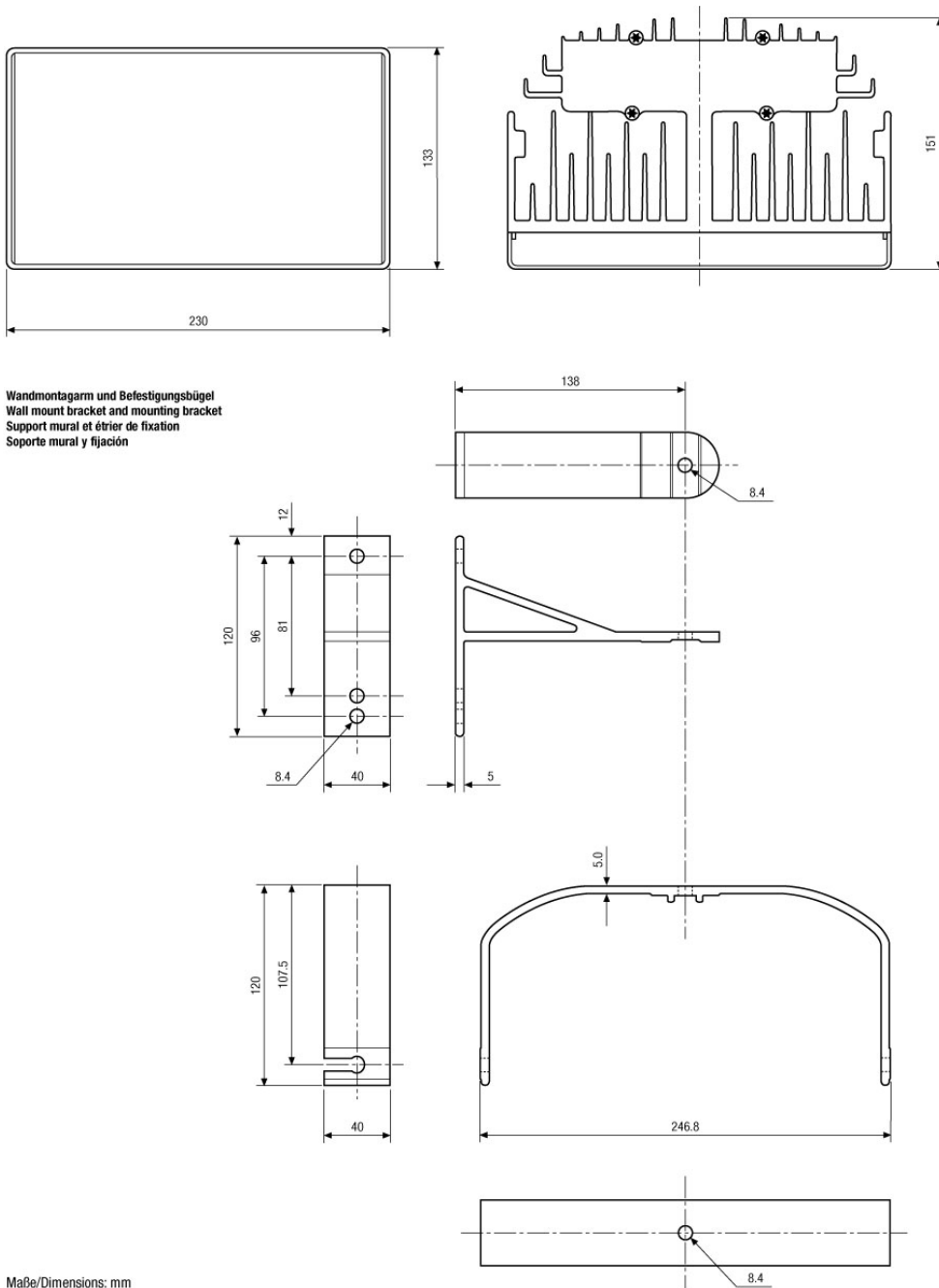

SLD Security & Communications  
The Old Forge, Ockham Lane, Ockham, Surrey GU236PH England  
Phone +44.1483225633 · Fax +44.1483225634  
sales@sld.co.uk · www.sld.co.uk

