

# CG-811PA1V

Home | Security | Cameras | Boxed

CG-811PA1V  
1/3" Day&Night Camera, DSP, 540TVL, 12VDC/24VAC,

Art-Nr. 92513



Lens not included

## Main Features

<b>Resolution of 540 Horizontal Lines (Colour)</b>	<b>Automatic AI/DC Control Selection (Depend on Lens)</b>
<b>Automatic Gain Control (AGC)</b>	<b>Integrated Eclipse and Flickerless Function</b>
<b>High Sensitivity of 0.04Lux at F1.2 (B&amp;W)</b>	<b>Automatic White Balance with Hold Function (AWB)</b>
<b>Removable IR Cut Filter</b>	<b>Auto Blemish Compensation (up to 32 Pixels)</b>
<b>Back Light Compensation (BLC)</b>	<b>Adjustable Video Transmission Distance</b>
<b>Electronic Shutter Control (ESC)</b>	<b>Supply Voltage: 12VDC or 24VAC</b>

## Specifications

<b>System</b>	day&night
<b>Video standard</b>	CCIR/PAL
<b>Sensor size</b>	1/3"
<b>Imager</b>	CCD, Sony Super HAD Interline Transfer
<b>Active picture elements</b>	440,000, 752(H) x 582(V)
<b>Horizontal resolution</b>	540 TVL, (colour), 570TVL (b&w)
<b>Synchronization</b>	Internal/AC line lock
<b>Signal-to-noise ratio</b>	48dB (AGC OFF)
<b>Gamma correction</b>	0.6/1.0
<b>Sensitivity (at 50% video signal)</b>	0,4 Lux, (colour), 0.05Lux (B&W) at F1.2 (measured)
<b>Low speed shutter</b>	no
<b>Digital Noise Reduction (DNR)</b>	no
<b>Backlight compensation</b>	BLC, eclipser, ON/OFF switchable

# CG-811PA1V

(Continuation Specifications)

<b>Wide Dynamic Range (WDR)</b>	no
<b>White balance</b>	automatic/manually
<b>Blemish compensation</b>	Automatic blemish detection and compensation (for up to 32 pixels)
<b>Aperture Correction (APC)</b>	horizontal and vertical
<b>Flickerless function</b>	120sec., ON/OFF switchable
<b>IR cut filter</b>	switchable
<b>OSD function control</b>	OSD camera setup: Pixel correction, Eclipser, Day&Nigt, BLC, AWB, Chroma, ESC, AGC, Flickerless, Aperture, Masking (Window blanking), Transmission distance compensation
<b>Digital zoom</b>	no
<b>Lens mount</b>	CS mount
<b>Iris control</b>	Manual iris, Auto-Iris/DC controlled
<b>Auto exposure</b>	Automatic/Manual/flimmerfree/AGC
<b>External adjustments</b>	Flange focus Switch for setup menu
<b>Video outputs</b>	composite (CVBS), 1Vp-p, (C)VBS, 75ohms, BNC
<b>External connections</b>	Auto-/DC Iris (4 pin), Video (BNC), Day/Night switching (2 pin), Power input
<b>Serial interfaces</b>	no
<b>Camera mount</b>	1/4" - 20 UNC thread on top and bottom
<b>Supply voltage</b>	12VDC, 24VAC, (+/-15%) 50Hz
<b>Power consumption</b>	approx. 4.7watts at 12VDC 6.5watts at 24VAC
<b>Temperature range (operation)</b>	-10°C ~+50°C
<b>Dimensions (HxWxD)</b>	see drawing
<b>Weight</b>	200g
<b>Parts supplied</b>	4 pin Lens plug, Allen wrench key, Control adapter cable with open ends, Quick start guide and manual on CD
<b>Certificates</b>	CE, FSV

## Optional accessories

<b>47149</b>	<b>F0612NDDC-NFS</b>	F1.2/6mm DC Lens with No Focus Shift, 1/3" CS Mount
<b>43274</b>	<b>F03Z2.6DC-NFSHR</b>	F1.0/3-8mm DC Lens, Varifocal, No Focus Shift, High Resolution, 1/3" CS Mount
<b>47148</b>	<b>F0412NDDC-NFS</b>	F1.2/4mm DC Lens with No Focus Shift, 1/3" CS Mount
<b>70769</b>	<b>WD-22</b>	Wall Mount Bracket with Ball Joint, 1/4" Camera Fixing Screw, Beige Grey
<b>70495</b>	<b>VT-PS12DC-7</b>	Plugable PSU w. Cont. & UK Mains plug-in 100-240VAC/12VDC-1.25A, Regulated
<b>77773</b>	<b>VT-PS12DCDT1</b>	PSU 12VDC/1.0A, Regulated, Desktop Version, 1.8m Cables each w. open ends
<b>70536</b>	<b>VT-PS12DC-9</b>	Plug-in Power Supply Unit 100-240VAC 12VDC (1.0Amp), Regulated, w. open Ends

## CG-811PA1V

43238	F03Z2.710DC-NFS	F1.0/3-8mm DC Lens/var. Focal Length with No Focus Shift, 1/3"CS Mount
43106	C/CS RING-AL	Adapter Ring, C/CS Mount, Aluminium anodized
43249	F07Z07NDDC-NFS	F1.3/7.5-50mm DC Lens/var. Focal Length with No Focus Shift, 1/3"CS Mount
43237	F03Z04NDDC-NFS	F1.4/2.8-11mm DC Lens/var. Focal Length No Focus Shift, 1/3"CS Mount
47154	F0812NDDC-NFS	F1.2/8mm DC Lens with No Focus Shift, 1/3"CS Mount
47147	F0312NDDC-NFS	F1.2/2.8mm DC Lens with No Focus Shift, 1/3"CS Mount
47161	F0212NDDC-NFS	F1.2/2.2mm DC Lens with No Focus Shift, 1/3"CS Mount
70771	WD-23	Wall Mount Bracket with Ball Joint, 1/4" Camera Fixing Screw, Pantone 877

# CG-811PA1V

Home | Security | Cameras | Boxed

## Technical drawing

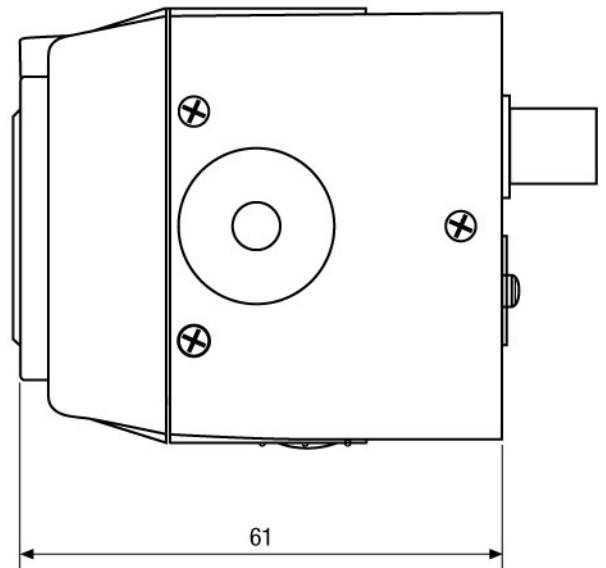
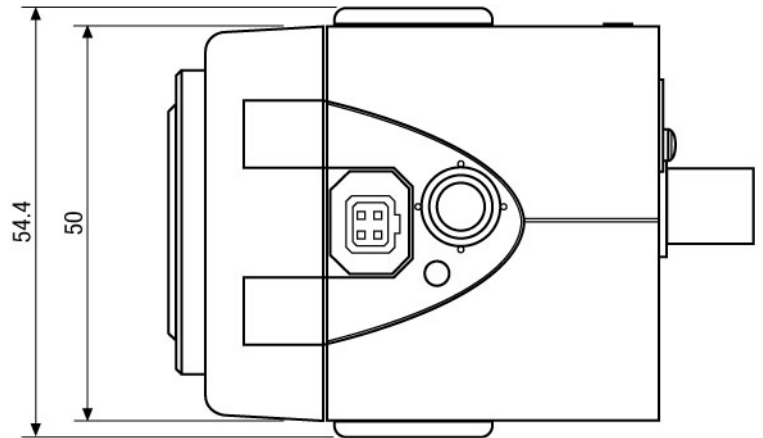
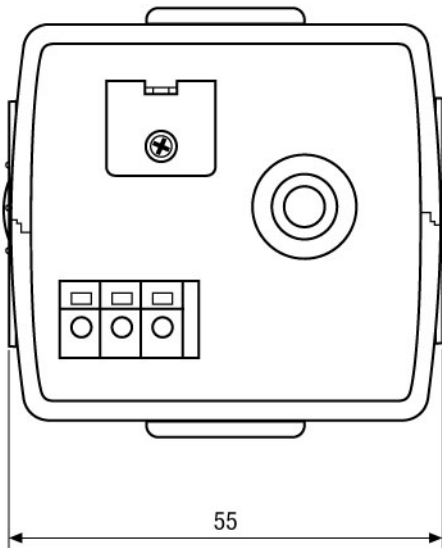

Maße/Dimensions: mm

SLD Security & Communications  
The Old Forge, Ockham Lane, Ockham, Surrey GU236PH England  
Phone +44.1483225633 · Fax +44.1483225634  
sales@sld.co.uk · www.sld.co.uk

