

# VHM/ECLKA-210-W

Home | Security | Housings | for Boxed Cameras

VHM/ECLKA-210-W  
Weatherproof Housing (210mm), Heater, CBD,  
RAL9016/7035, 230VAC

**Art-Nr. 79675**



## Main Features

Camera weather protection	3 cable entries M16x1.5mm
Housing body length: 210mm	PTC window heater 100-265V included
Fold-down housing body	Window glass with "Clear-Shield" technology
4 levels of camera height adjustment	Incorporated carrier handle
Insulated camera mounting	Protection rating: IP66
Integrated connection board	Housing colour: RAL9016/RAL7035

## Specifications

Series	eneo VHM
Maximum installation length	210
Space for power supply	NE-112 (1 output): 85mm; NE-112/2 (2 outputs): 110mm
Cable entries	3x M16x1.5mm
Window screen	Coated with "Clear Shield" Technology. With this technology the glass corrosion, caused by environmental pollution, is avoided and screen cleaning cycles will be extended. The coating is UV light resistant, colour neutral and it causes no F-stop loss.
Clear Shield	yes
Window heater	yes, 110~265VAC/9watts (PTC)
Thermostat	On: +16°C, Off: +20°C
Blower	no
Wiper	no
Supply voltage	100~240VAC

# VHM/ECLKA-210-W

(Continuation Specifications)

<b>Sunshield</b>	yes
<b>Hidden cable management</b>	no
<b>Integrated wall mount</b>	no
<b>Protection rating</b>	IP66
<b>Housing</b>	outdoor
<b>Housing material</b>	aluminium
<b>Housing</b>	Aluminium with plastic covers (ABS)
<b>Colour (housing)</b>	RAL9016, RAL7035
<b>Temperature range</b>	-30 to +60°C
<b>Dimensions (HxWxD)</b>	125x133x353mm
<b>Weight</b>	2.2kg
<b>Parts supplied</b>	Screw set, Thermostat switch, Screw terminal

## Optional accessories

<b>70457</b>	<b>AK-3</b>	Camera Connection box, 230VAC Input, 24VAC-3.2A, 12VDC-1A Outputs
<b>79364</b>	<b>NE-112</b>	Power Supply Unit 230VAC/12VDC (600mA) for VHM Housing, Regulated
<b>79491</b>	<b>NE-112/AC24V</b>	Power Supply Unit 230VAC/24VAC (600mA) for VHM Housing
<b>79423</b>	<b>NE-112/2</b>	Power Supply Unit 230VAC/12VDC (600mA), Regulated, 24VAC (1000mA) f. VHM Housing
<b>73177</b>	<b>WD-16/MK-W</b>	Wall Mount with Swivel Head for VHM Weatherproof Housings, RAL9016

# VHM/ECLKA-210-W

Home | Security | Housings | for Boxed Cameras

## Technical drawing

79416

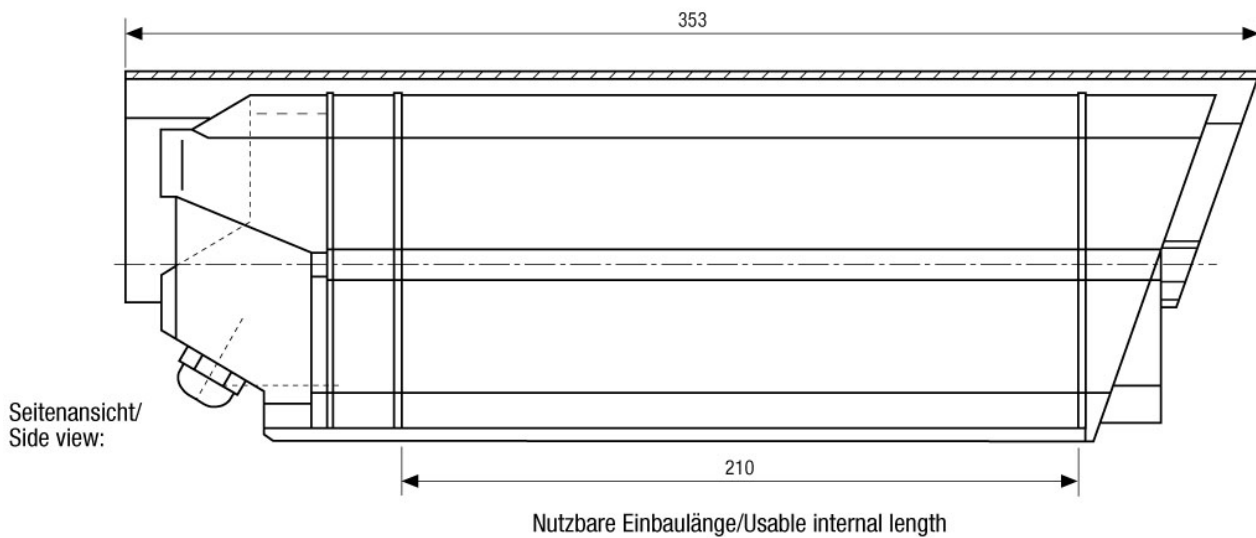
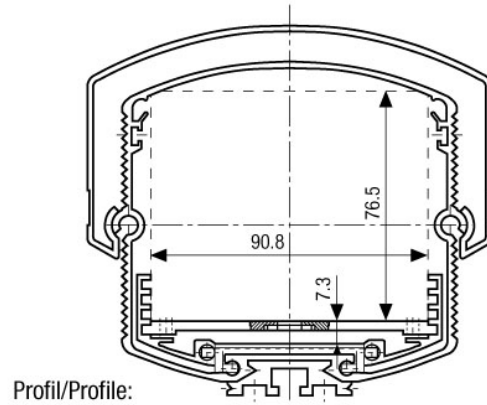
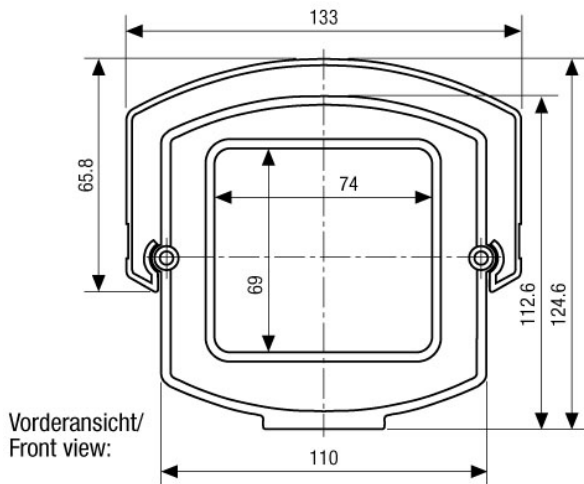

Maße/Dimensions: mm

SLD Security & Communications  
The Old Forge, Ockham Lane, Ockham, Surrey GU236PH England  
Phone +44.1483225633 · Fax +44.1483225634  
sales@sld.co.uk · www.sld.co.uk

