

VHM/ZLKCB-W

Home | Security | Housings | for Boxed Cameras

VHM/ZLKCB-W
Weatherproof Housing (330), 24V Heater, KV1,
Internal Pre-wiring, RAL9016/7035

Art-Nr. 79683



SLD Security &
Communications

Main Features

Camera weatherproof housing with window heater
Fold-down housing body
4 levels of camera height adjustment
Insulated camera mounting
Central connector with 30 pin contact strip
Cable entry with metal gland M25x1.5mm

Pre-wired for 24VAC supply via VPT-501/601
With screw terminal board VHM/KV1
Prepared for easy camera and lens assembly
Window glass with "Clear-Shield" technology
Housing colour: RAL9016/RAL7035
Option: P/T head connection cable

Specifications

Series	eneo VHM
Maximum installation length	330
Window screen	Coated with "Clear Shield" Technology. With this technology the glass corrosion, caused by environmental pollution, is avoided and screen cleaning cycles will be extended. The coating is UV light resistant, colour neutral and it causes no F-stop loss.
Clear Shield	yes
Window heater	yes, 24V (12V), 6watts
Thermostat	On: +16°C, Off: +20°C
Blower	no
Wiper	no
Supply voltage	12~24V
Sunshield	yes
Hidden cable management	no

VHM/ZLKCB-W

(Continuation Specifications)

Cable entry	Metal gland M25x1.5mm (for cable diameter 9~17mm)
Cable connection	30-pin central plug
Integrated wall mount	no
Protection rating	IP66
Housing	outdoor
Housing material	aluminium
Housing	Aluminium with plastic covers (ABS)
Colour (housing)	RAL9016, RAL7035
Temperature range	-30 to +60°C
Dimensions (HxWxD)	see drawing
Weight	2.9kg
Parts supplied	Housing 330mm, Central plug with built-in 30-pin female connector, Screw set
Special feature	Pre-wired internally for easy 24VAC camera and zoomlens installation.

Optional accessories

70457	AK-3	Camera Connection box, 230VAC Input, 24VAC-3.2A, 12VDC-1A Outputs
73177	WD-16/MK-W	Wall Mount with Swivel Head for VHM Weatherproof Housings, RAL9016

VHM/ZLKCB-W

Home | Security | Housings | for Boxed Cameras

Technical drawing

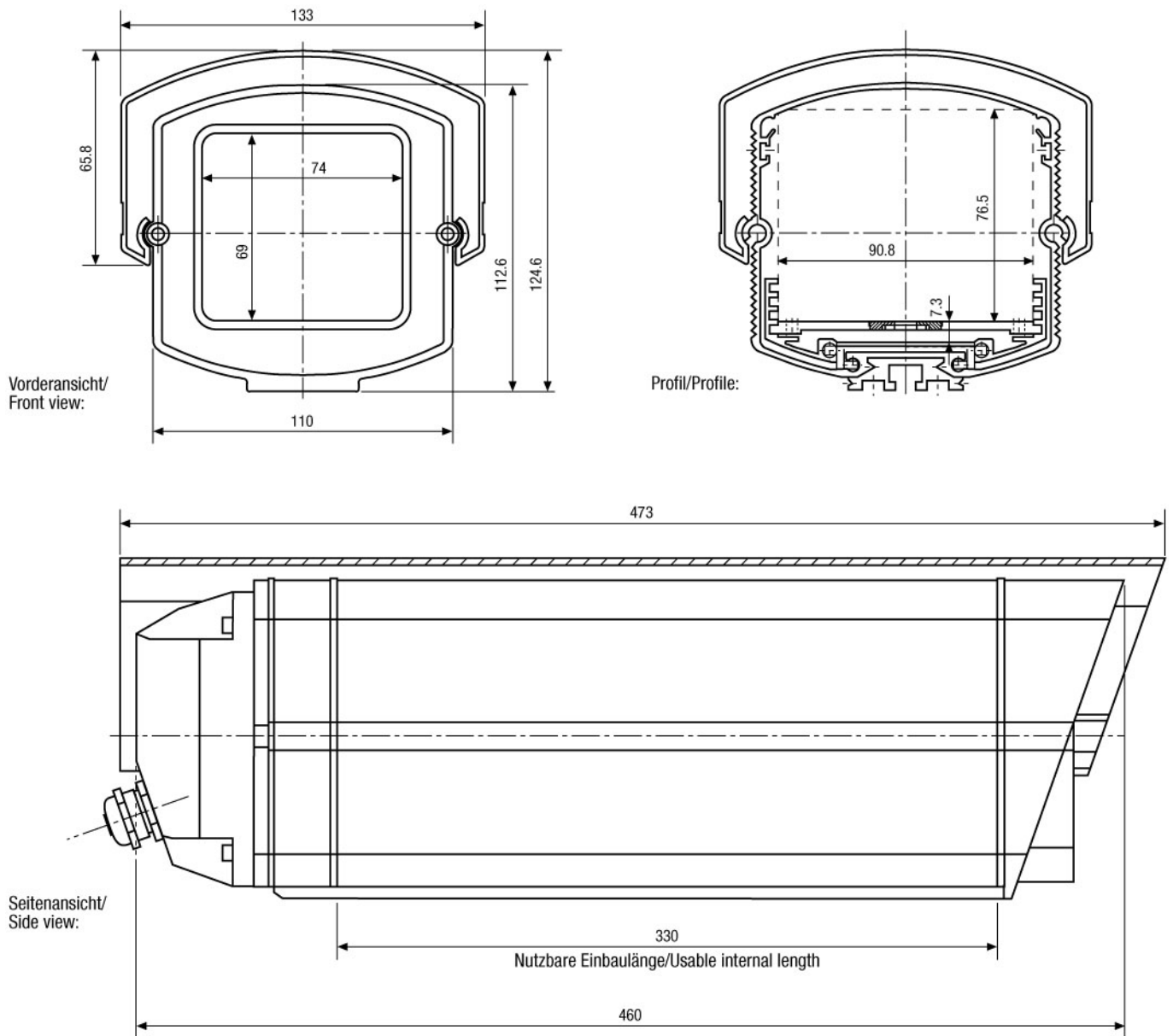

Maße/Dimensions: mm

SLD Security & Communications
The Old Forge, Ockham Lane, Ockham, Surrey GU236PH England
Phone +44.1483225633 · Fax +44.1483225634
sales@sld.co.uk · www.sld.co.uk

