

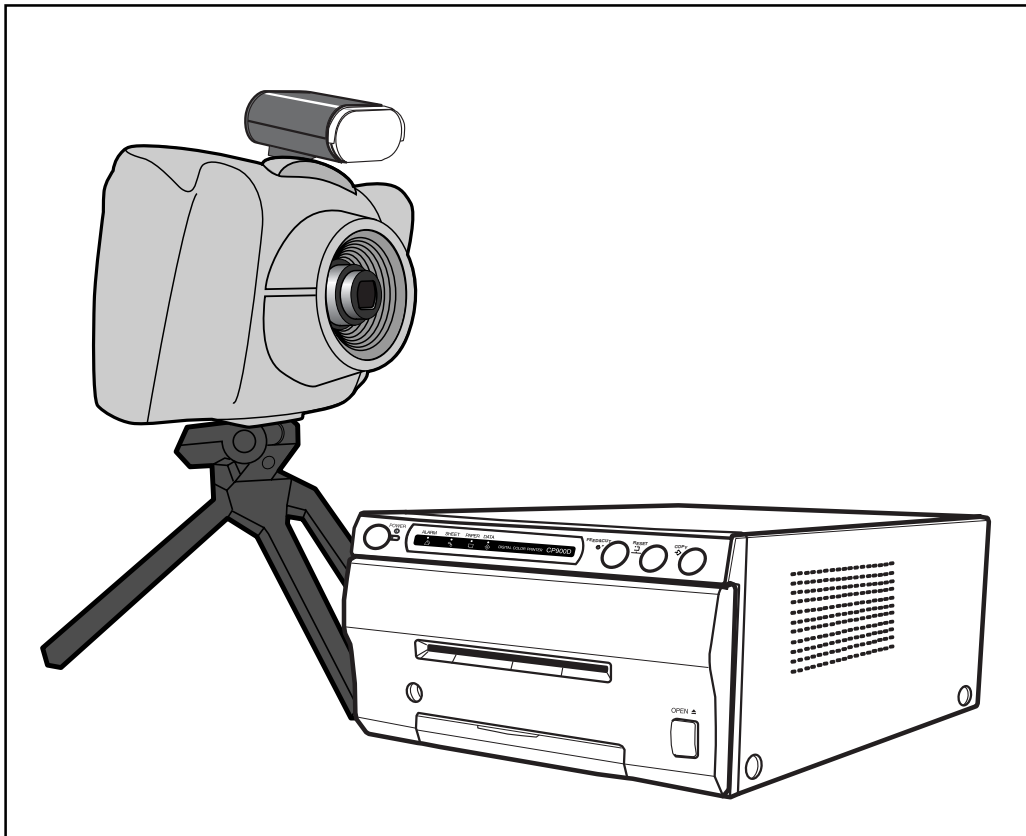

PHOTO ID SYSTEM

900D-ID

[DIS900D+CP900DW(ID)]

OPERATION MANUAL



SLD Security & Communications
The Old Forge, Ockham Lane, Ockham, Surrey GU23 6PH England
Phone +44.1483225633 · Fax +44.1483225634
sales@sld.co.uk · www.sld.co.uk





CONTENTS

	Page
1 SAFETY PRECAUTIONS	3 - 5
2 UNPACKING	6
3 PRINTER SETUP	7 - 9
4 CONNECTION	10
5 TAKING A PICTURE	11 - 13
6 PICTURE QUALITY ADJUSTMENT	14 - 19
7 FEATURES AND FUNCTIONS	20 - 21
8 ADVANCED SETTING	22 - 31
9 TROUBLESHOOTING	32 - 34
10 SPECIFICATIONS	35

CONTENTS

This system is composed by the following components.

Printer

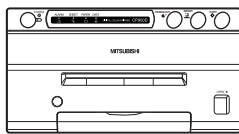

Printer

- AC cable
- Operation manual
- Ink cassette
- Printer driver
- Spacers
- Screws

System



Camera

- System cable
- Operation manual

Options

(not provided from Mitsubishi)

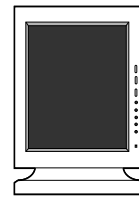

Monitor



Tripod

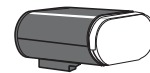

Flash

This system complies with the requirements of the EC Directive 89/336/EEC "EMC Directive" as amended by Directive 93/68/EEC.

The electro-magnetic susceptibility has been chosen at a level that gains proper operation in residential areas, on business and light industrial premises and on small-scale enterprises, inside as well as outside of the buildings. All places of operation are characterised by their connection to the public low voltage power supply system.



1. SAFETY PRECAUTIONS

In the interest of safety, please observe the following precautions:

POWER REQUIREMENT

This system is designed for operation on 120V AC or 220V-240V, 50/60Hz AC. Never connect to any outlet or power supply having a different voltage or frequency.

WARNING: THIS APPARATUS MUST BE EARTHED.

AVERTISSEMENT: CET APPAREIL DOIT ETRE MIS A LA TERRE.

PROTECTIVE MEASURES

IF ABNORMALITIES ARISE,

Use of the unit during emission of smoke or abnormal sounds (without adopting countermeasures) is dangerous. In such a case, unplug the power cord from the source outlet immediately, and request maintenance service from the sales dealer.

NEVER INSERT ANY OBJECT INTO THE UNIT

Foreign objects of an kind inserted into this unit constitute a safety hazard and can cause extensive damage.

DO NOT PLACE ANYTHING ON THE DIGITAL COLOR PRINTER

Heavy objects placed on the Digital color printer can cause damage or obstruct proper ventilation.

PROTECT THE POWER CORD

Damage to the power cord may cause fire or shock hazard. When unplugging, hold by the plug only and remove carefully.

DO NOT PLACE WATER CONTAINERS ON THE UNIT

Do not place flower vases, and other water-holding containers on the device. If, for some reason, water seeps to the inside of the unit, unplug the power cord from the source outlet, and contact the sales dealer. If used without corrective measures, the unit may be damaged.

"In the interest of safety, avoid handling of liquids near the unit."

DO NOT REMOVE THE CABINET

Touching internal parts is dangerous, and it may lead to malfunction. Contact the sales dealer to carry out internal checks and adjustments. Before opening the cover to remove jammed paper, etc., be sure to disconnect the power cord plug.

UNPLUG THE POWER CORD IF THE UNIT IS NOT IN USE

Turn off the MAIN power switch and unplug the power cord if the unit is not in use for extended periods.

WHEN TRANSPORTING THE UNIT

When transporting the unit, remove the sheet cartridge and paper from the paper cassette.

BE CAREFUL AROUND PRINT PAPER EXIT SLOT

Don't insert your hand or any material into the paper exit slot during printing.
Don't touch the cutter blade inside the paper exit slot as this can cause injury.

DO NOT TOUCH THE THERMAL HEAD

Do not touch the thermal head (located inside the unit).
The thermal head is heated to high temperature and may cause injury.



BE CAREFUL WITH THE PRINTING UNIT

Don't move the unit while the drawer is open. This may cause injury.
Be careful not to catch your finger in the printing unit while the drawer is being closed.

CONNECTION CABLES

Only use the cables provided.

INSTALLATION LOCATIONS

MAINTAIN GOOD VENTILATION

Ventilation slots and holes are provided on the top, sides and bottom of this unit. Place the unit on a hard and level surface and locate at least 10 cm from walls to insure proper ventilation. When putting the unit on the system rack, ensure there is a space between the unit and the back of the rack.

UNSUITABLE LOCATIONS

Avoid uneven surfaces or hot-springs areas where hydrogen sulfide and acidic ions are likely to be generated.

PLACES WITH HIGH HUMIDITY AND DUST

Do not place the unit in locations with high humidity and dust. They can cause extensive damage. Avoid places where unit is likely to be exposed to oily fumes and vapours.

PLACES LIKELY TO BE EXTREMELY HOT

Places exposed to direct sunlight, or near heating appliances can attain extremely high temperatures, which may deform the cabinet, or cause other damage.

PLACE THE UNIT ON A HORIZONTAL SURFACE

The unit is likely to be affected if it is placed in slanted conditions or in unstable places.

PROTECT AGAINST DEW FORMATION

In extremely cold regions, if the unit is moved quickly from an extremely cold place to warmer one, dew is likely to be formed.

If dew is formed, printing is not possible.

OPERATING AMBIENT TEMPERATURE RANGE

The operating ambient temperature range is 5°C- 40°C, and humidity of 20-80%. When using the unit on the system rack, be sure to keep this ambient temperature inside the rack.

FOR LONG OPERATING LIFE

UNSUITABLE MATERIALS FOR THE DIGITAL COLOR PRINTER

Coat flaking and deformation are likely to occur if the unit is wiped with chemical dusters, benzine, thinner or any other solvent, if rubber or PVC items are left in contact with the unit for extended duration, or if the unit is sprayed with insecticide.

CARE OF THE CABINET

Unplug and clean with a soft cloth slightly moistened with a mild soap and water solution. Allow to dry completely before operating. Never use petroleum based solutions or abrasive cleaners.

HEAD ABRASION

The thermal head, like the video head, wears out. When it is abraded, it becomes hard to print out fine details of the picture. In such a case, it is necessary to replace the thermal head. Consult with the sales dealer for replacing the head.



CAUTION ON RELOCATING

When transporting this unit, make sure it is not likely to be subjected to impacts. They can be a prime cause for damage. Also, make sure to disconnect the power cord from the power outlet, and all cables from the devices.

CONNECTING DEVICES

Read thoroughly "Operating Precautions" of the instruction booklets for the devices connected with the Digital color printer.

The power cord must be disconnected after printing is over.

OTHER CAUTIONS

Dust or other foreign matter adhering to the print paper or the sheet cartridge, or deformation resulting from exposure to extremely low or high temperatures could cause loss of colour, uneven colour or lines, or wrinkles in the print images.

NOTE:

YOUR UNDERSTANDING IS REQUESTED FOR THE LOSS OF IMAGES IN MEMORY DUE TO THE SUDDEN OCCURRENCE OF A MALFUNCTION.

WHEN USING A COMPACT FLASH™

1. To use the Compact Flash,

1. Insert a Compact Flash into the camera.

2. Turn on the power.

To pull out a Compact Flash,

1. Turn off the power.

2. Pull out the Compact Flash.

The camera is turned on	
with a CF inserted	without a CF inserted
CF is available.	CF is not available.

* CF : Compact Flash

2. When a Compact Flash is inserted or pulled out during power on status, the Compact Flash and the camera may be damaged.

Make sure to turn off the power when inserting or pulling out the Compact Flash.

3. Compact Flashes recommended

Manufacturer : Mitsubishi, SanDisk, LEXAR

Capacity : 8M byte, 16M byte, 32M byte, 64M byte

- Compact Flash is a trademark of SanDisk Corporation.



2. UNPACKING

Take the unit out of the box by the following procedures. Make sure to check the contents.

■ PRINTER

- 1 Open the top of the box.
- 2 Remove the accessory box.
- 3 Remove the cushion above the unit.
- 4 Take the unit out of the box carefully.
Make sure to keep the unit horizontal.
Then, unwrap the packing.

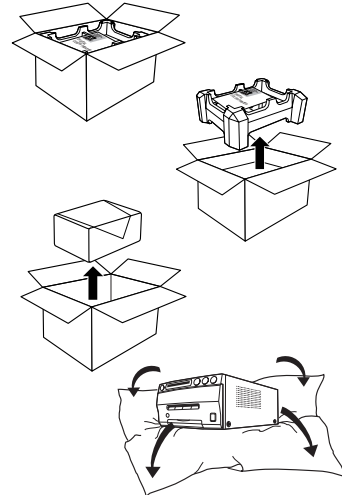

• Accessory box

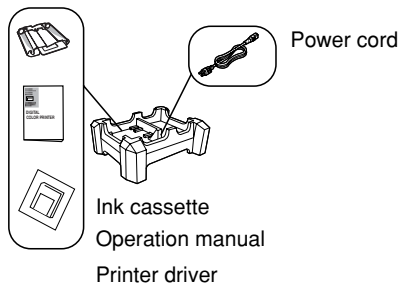

■ CAMERA, ETC.

- 1 Open the top of the box.
- 2 Take out the system cable and operation manual.
- 3 Remove the top cushion.
- 4 Take the camera out of the box carefully.

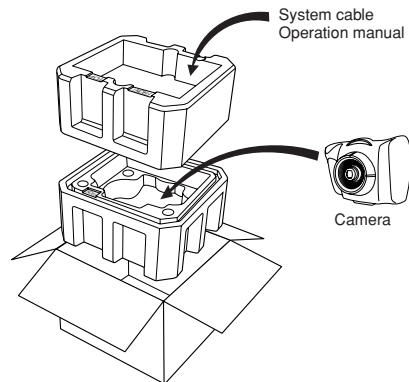



3. PRINTER SETUP

Before printing a photo, install print paper and ink cassette.

UNLOCK THE PRINTING UNIT

See CP900DW(ID) operation manual for details.

RELEASING THE PRINTING UNIT LOCK

1 Press down the knob to pull out the tray.

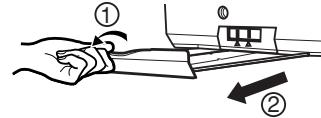

2 Shift the printing unit lock switch to the right (UNLOCK).

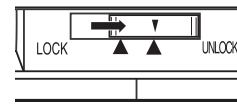

INSTALLING PRINT PAPER

Do not remove the seal on the print paper yet.

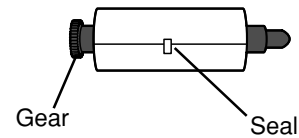

1 Insert the print paper roller with gear on the left.

Press the folder 1 as shown right, and set the print paper roller.

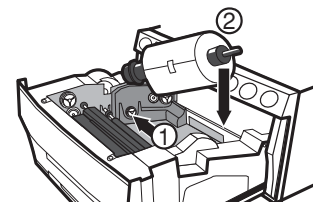

Front side

2 Set the other side of roller without gear.

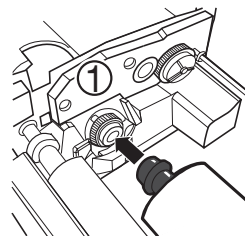

Left side

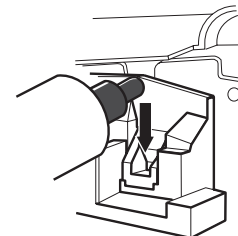

Right side



- 3 Remove the seal, and insert the edge of the print paper right below the roller cover with arrow marks towards the front panel.**

Make sure to insert the paper straight.

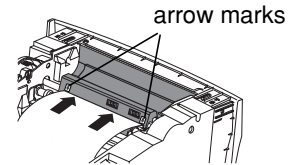

- 4 Feed the print paper through the paper outlet by hand.**

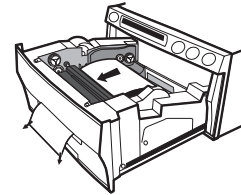

- 5 Pull both sides of the print paper to eliminate slack.**

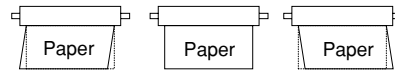

INCORRECT CORRECT INCORRECT

INSTALLATION OF INK SHEET

INSTALLING THE INK SHEET

Load the ink sheet into the cassette before inserting the cassette into the printer.

- 1 Put the ink sheet rollers with flat tops into the holes of ink cassette.**

Put the white roller (rolled with ink sheet) to the ink cassette first. Then, put the colored roller (without ink sheet) to the ink cassette.

colored roller white roller

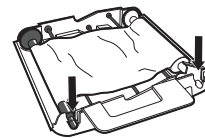
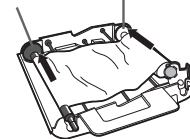

- 2 Position the other sides of rollers. Set IC at this time.**

IC chip with the IC holder is attached to the ink sheet. Set the IC holder to the ink cassette as shown right.

NOTE

- Do not remove the IC chip or IC holder from the ink sheet. Removal of the IC will stop the printer from functioning correctly.
- Set the projected part of the IC holder to the correct position as shown below.

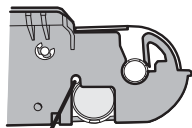
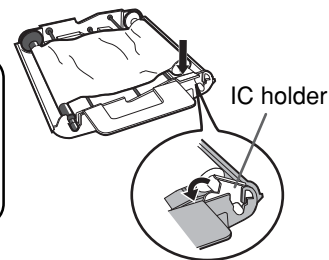

8 Projected part



■ INSTALLING THE INK CASSETTE

1 Eliminate any slack of the ink sheet.

Hold the colored roller and turn the white roller.

2 Insert the ink cassette with the ink sheet into its compartment.

Put the ink cassette with flat top side to each ①. Then, set the other side (with handle) as shown right. When exchanging the ink sheet, remove the cassette by holding the handle.

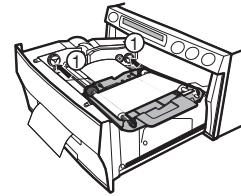
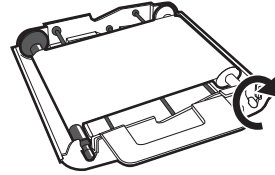

■ INSERT THE PRINTING UNIT

1 Push the printing unit until it is locked into place.

2 After plugging the power cord, press POWER button on the front panel.

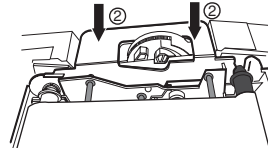

3 Press FEED&CUT button.

The print paper is automatically cut after feeding about 10 cm (4 inches).

4 Repeat the above step 3 once or twice.

Feeding the print paper will eliminate fingerprints and dust during handling. The printing unit is initialized.

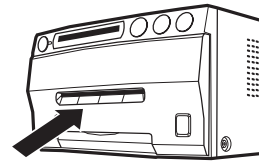

NOTE

An IC is built in the ink sheet. This is the IC chip, not a battery. This IC is safe to be thrown away with normal waste.



4. CONNECTION

CABLE CONNECTION

Connect the components as follows.(example)
 Make sure to turn off each device when connecting.
 After connecting the cables, make sure to set the cover over the terminals on the camera.
 (See page 21 for removing and setting the cover.)

900D-ID

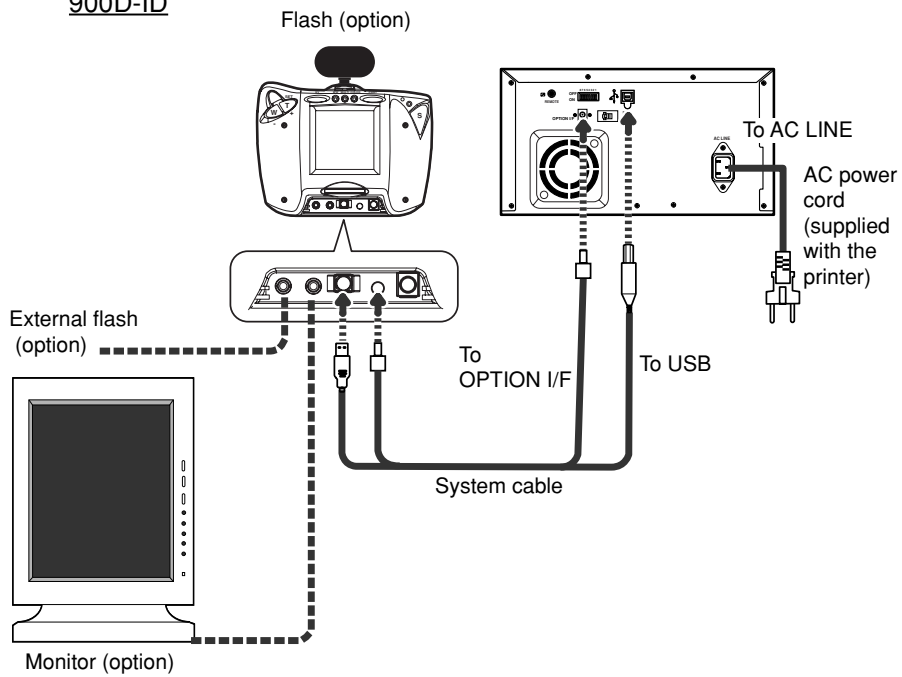

DIS900D+DPS

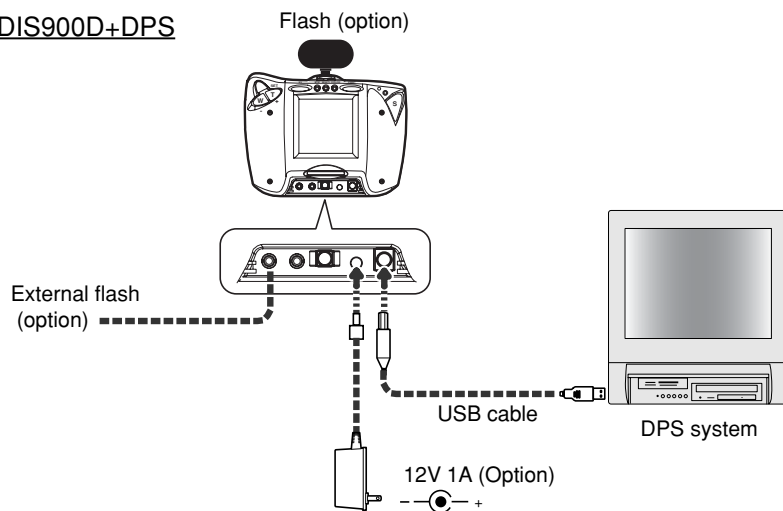



5. TAKING A PICTURE

You can take up to four pictures (without Compact Flash), and choose the best one.

1 Connect the camera and the printer.

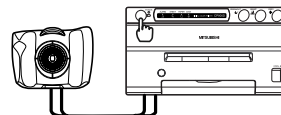

2 Turn on the printer.

The camera is also turned on.

3 Switch the camera to CAMERA mode.

- When the camera is turned on, it is set to CAMERA mode.
- If PLAY mode is selected, press CAMERA/PLAY button.
- The printing area, face guide, multi format setting, color setting and memory position are displayed.

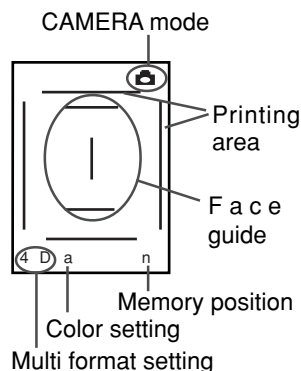

4 Select the type of multiple picture (1, 2, 4, 4D, 6, 16 or 1L) by MULTI button.

Each time the button is pressed, the format changes.

- | | | | |
|------|---------------------|---|---------------------|
| 1 | 1-image (75x100mm) | 2 | 2-image (50.8x74mm) |
| 4,4D | 4-image (36.5x48mm) | 6 | 6-image (30x35mm) |
| 16 | 16-image (19x25mm) | | |

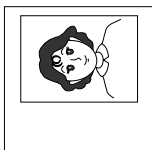

1



2

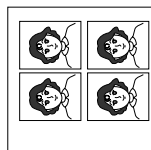

4

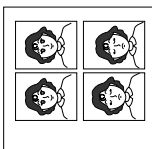

4D

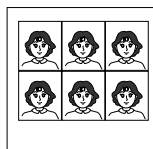

6

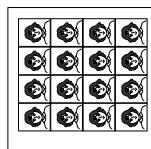

16

5 Press T (+) or W (-) button to adjust the size to fit the face in the face guide.

Adjust the position where:

- The face is positioned just within the upper and lower horizontal lines on the LCD.
- The nose is aligned with the vertical line at the center of the LCD.

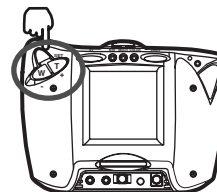
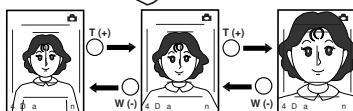
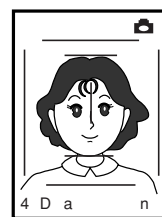



6 Press EV button to adjust brightness when taking picture.
EXP. is displayed.

- If FLASH : OFF is selected on CAPTURE menu, EV is displayed.

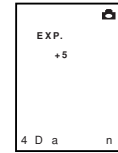

7 Press T (+) or W (-) button to adjust the brightness.
To make an image brighter, increase the value.
To make an image darker decrease the value.

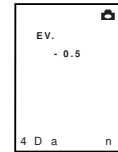

8 Press SET button.

9 Press SHOT button halfway to adjust focus.
During focus adjusting, the focus mark (●) appears.
When focus is adjusted, the focus mark disappears.

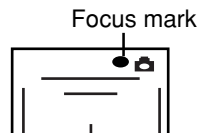

10 Press SHOT button down completely to take a picture.
The image is memorized in the camera.

The camera is switched to PLAY mode. A mark ► will be displayed.

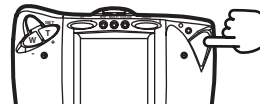

Total number of images
(when using Compact Flash)



Position the image memorized
(when not using Compact Flash)

PLAY mode mark

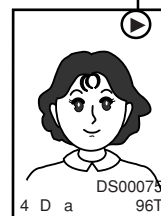

- Four images can be memorized in the camera.
- When a Compact Flash is inserted, the images are memorized only in the Compact Flash.

11 When taking more pictures, press CAMERA/PLAY button.
Switch the camera to CAMERA mode. Then, repeat the above steps 9 to 10.

- If brightness of the image is not adjusted correctly, repeat the above steps 6 to 10.

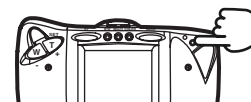



12 Switch the camera to PLAY mode to print a picture.

Press CAMERA/PLAY button.

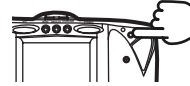

13 Select the image to be printed.

Press T (+) or W (-) button to select the image.



14 Print the image.

Press PRINT button.

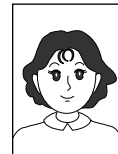
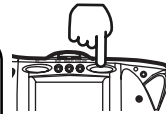

Printed image

NOTE

When printing the images in 4D mode, the printing procedure is as follows.

1. Select or take the first image and press PRINT button. The first image is transferred to the printer.
2. Select or take the second image and press PRINT button. The second image is transferred to the printer and printing the two images starts.

Refer to page 14 to get maximum quality of your pictures.

Deleting the memorized images (when using a Compact Flash)

1 Set the camera to PLAY mode.

2 Display the image to be deleted by pressing T (+) or W (-) button.

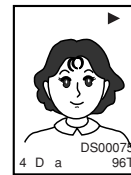

3 Press SET button.

The image to be deleted is selected.



4 Select ONE or ALL by pressing T (+) or W (-) button.

When selecting ONE, the image displayed will be deleted.

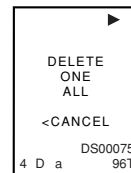

5 Select YES and press SET button.

The image is deleted.

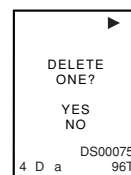
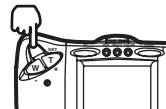

NOTE

When selecting ONE to delete the images one by one, "No image for this MODE" will appear. In this case, some images may remain in another MODE.

e.g. When 5 images remain in HS mode (MODE1) and 3 images in >1.6m mode (MODE2) :

Though all the images in HS mode are deleted by selecting ONE, 3 images in >1.6m mode remain in the memory.

See page 28 for MODE1 and MODE2.



6. PICTURE QUALITY ADJUSTMENT

ADJUSTING PICTURE QUALITY

Adjusting the image source first is the key to get maximum picture quality.

CAMERA ADJUSTMENT

Always adjust the camera setting first. Only after you are sure that the camera is providing the best picture quality and color balance, should you adjust the printer setting.

Make sure to adjust the camera setting in the same condition which you actually take a picture.

ADJUSTING THE CENTER VALUE OF THE IMAGE BRIGHTNESS

1 Press CAMERA/PLAY button to select CAMERA mode.

2 Press T(+) or W(-) button to set the zoom.

3 Press SET button for more than 3 seconds.
MENU is displayed.

4 Press T(+) or W(-) button to select CAPTURE.

5 Press SET button.
The CAPTURE menu is displayed.

6 Press T(+) or W(-) button to select FLASH : ON and press SET button.
EXP. CENTER menu appears.

- If OFF is selected on FLASH, EXP. CENTER menu does not appear.

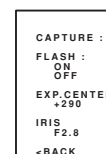

```
MENU
WB
COLOR
SHARP
LCD
CAPTURE
MODE
TRIM

S.MENU
RESET
<EXIT
```

```
CAPTURE :
FLASH :
ON
OFF
EXP.CENTER
+290
IRIS
F2.8
<BACK
```

```
CAPTURE :
FLASH :
ON
OFF
EXP.CENTER
+290
IRIS
F2.8
<BACK
```

```
CAPTURE :
FLASH :
ON
OFF
ST.
1 / 125
IRIS
F2.8
<BACK
```

FLASH : ON FLASH : OFF



7 Change EXP. CENTER value.

Repeat increasing the EXP.CENTER value by 5 starting from 260. (Use T(+)) button to increase the value.)
Take a picture and check the brightness in the picture at every increase of the EXP.CENTER value.
As the EXP. CENTER value increases, the image gets brighter, however, the image stops getting brighter at a certain value.
This is the maximum EXP. CENTER value.



8 Set EXP. CENTER value.

Decrease the maximum EXP. CENTER value by 5. Set this value as EXP. CENTER. (Use W(-)) button to increase the value.)
The value decreased from the maximum EXP. CENTER value depends on the flash in use.



9 Press SET button.



10 Press T(+) or W(-) button to select <BACK to finish the iris setting menu.



11 Press SET button.





■ ADJUSTING THE COLOR OF IMAGE (WHITE BALANCE)

Default setting is flash light W.B. If you are not satisfied with this setting, please proceed as follows.

- 1 Place a piece of white paper in front of the camera and display it to cover the LCD.**

Place the white paper at the actual position of a person who is taking a picture from the camera.

NOTE

The memorized picture should not be completely white. It is necessary that the picture is a little bit dark, means slightly gray.
Also, the back flash should be turned off.

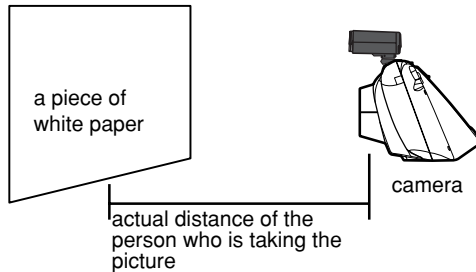

- 2 Take a picture.**
Press SHOT button.

- 3 Press CAMERA/PLAY button to switch the camera to CAMERA mode.**

- 4 Press SET button for more than 3 seconds.**
MENU is displayed.

- 5 Press T(+) or W(-) button to select WB.**

- 6 Press SET button.**
The WB menu is displayed.

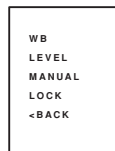



- 7** Press T(+) or W(-) button to select LOCK and press SET button.
LOCK menu appears.

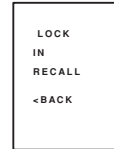
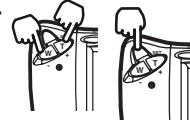

- 8** Press T(+) or W(-) button to select IN and press SET button.
The camera automatically starts adjusting white balance, and completes setting in a few seconds.

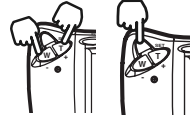

- 9** Repeat pressing T(+) or W(-) button to select <BACK then press SET button to finish the white balance setting menu.





■ FINE-ADJUSTING OF COLOR

- 1 Press SET button for more than 3 seconds.**
MENU is displayed.



```

MENU
WB
COLOR
SHARP
LCD
CAPTURE
MODE
TRIM

S.MENU
RESET
<EXIT

```

- 2 Press T(+) or W(-) button to select COLOR.**



- 3 Press SET button.**
The COLOR menu is displayed.
If B/W button on the camera is pressed, B/W menu is displayed.



COLOR :	B / W :
a	a
b	b
c	c
<BACK	<BACK

- 4 Press T(+) or W(-) button to select a, b or c, then press SET button.**



- 5 Change the value of each item to get the best color.**
COLOR :
R Adjusts red-subcontrast of the printed image.
B Adjusts blue-subcontrast of the printed image.
HUE Adjusts tint of the printed image.
STEP Sets the variation of R, B and HUE.



- B/W :
Y Adjusts yellow-subcontrast of the printed image.
M Adjusts magenta-subcontrast of the printed image.
C Adjusts cyan-subcontrast of the printed image.

COL -a	B / W -a
R : 0	Y : 0
B : 0	M : 0
HUE : 0	C : 0
STEP : 0	
TEST	
PRINT	
<BACK	<BACK

- 6 Press SET button.**
The changed value is saved.



```

COLOR :
a
b
c

<BACK

```

- 7 Select <BACK by pressing T (+) or W (-) button, then press SET button.**
MENU is displayed.



```

MENU
WB
COLOR
SHARP
LCD
CAPTURE
MODE
TRIM

S.MENU
RESET
<EXIT

```



8 Select <EXIT and press SET button to go back to CAMERA mode.

If you wish to reset the settings, select RESET. Then select YES and press SET button.





7. FEATURES AND FUNCTIONS

CAMERA (FRONT)

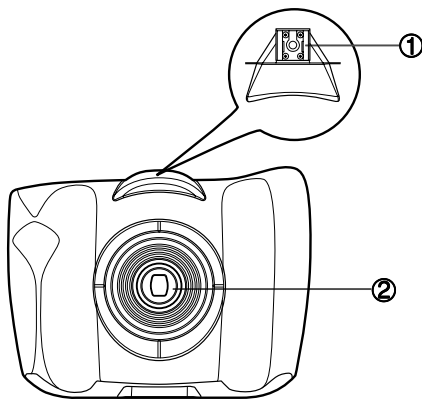

- ① FLASH SOCKET
- ② LENS

CAMERA (REAR)

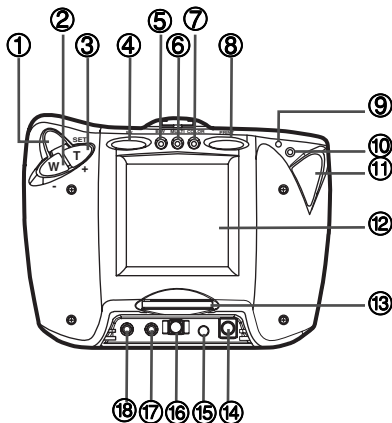

- ① **SET BUTTON**
Press for 3 seconds to display MENU. Press to select a menu item to be changed and save the settings. Repress to exit the menu mode.
- ② **W(-) BUTTON**
Press to zoom down an image or select a menu item. In PLAY mode, use to select the memorized picture.

- ③ **T (+) BUTTON**
Press to zoom up an image or select a menu item. On PLAY mode, use to select the memorized picture.
- ④ **EV BUTTON**
Press to change the exposure in Flash ON mode. In Flash OFF mode, the shutter speed can be changed. Set Flash ON or OFF on CAPTURE menu. (See page 27.)
- ⑤ **B/W BUTTON**
Press to select the black and white image setting.
- ⑥ **MULTI BUTTON**
Press to select multi image print. The mode changes in the order of 1, 2, 4, 4D, 6, 16, 1L. 1L is displayed when L-size is selected in MODE menu.
- ⑦ **COLOR BUTTON**
Press to select the image colour setting between a, b and c.



⑧ PRINT BUTTON

Press to print an image.

⑨ LED

Normally, this LED is green. It blinks in red during reading or writing an image in a Compact Flash. In sleep mode, it lights up in orange.

⑩ CAMERA/PLAY BUTTON

Switches the camera between CAMERA and PLAY modes. Press for more than 3 seconds to display the total number and remaining number of prints. (By pressing SET or CAMERA/PLAY button, the camera goes back to the normal display.)

⑪ SHOT BUTTON

Press halfway to adjust focus and press down full to take a picture.

⑫ LCD

Displays the source image, memorized image, multi mode, color or B/W setting number and memory position.

⑬ CF SLOT

Insert a Compact Flash here.

⑭ USB TERMINAL

Use this terminal when connecting to DPS system.

⑮ DC 12V TERMINAL

⑯ USB TERMINAL

Use to connect with CP900DW(ID) printer.

⑰ VIDEO OUT TERMINAL

Use to connect with a monitor.

⑱ EXTERNAL FLASH TERMINAL

CAMERA (BOTTOM)

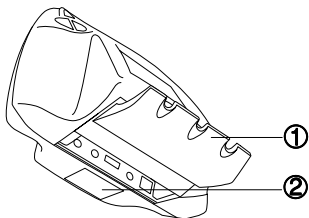

① TERMINAL COVER

② HOLE TO ATTACH TRIPOD

How to remove and set the terminal cover

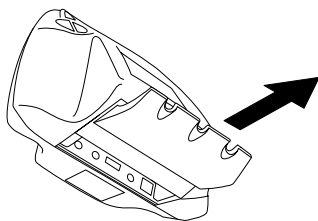

Slide out the cover straight.

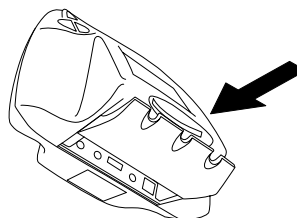

Push the cover toward the camera.



8. ADVANCED SETTING

MENU CHART

SET shows the button names on the camera.

Select ON or OFF with + or - button.

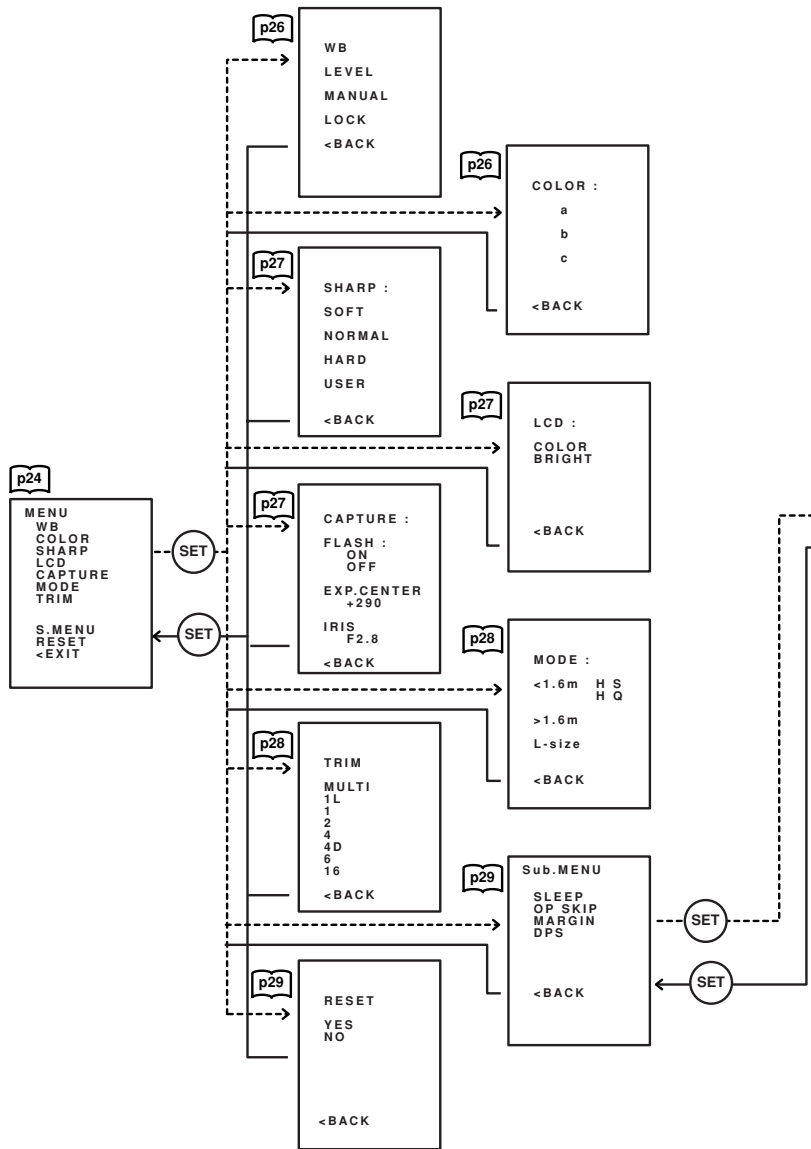

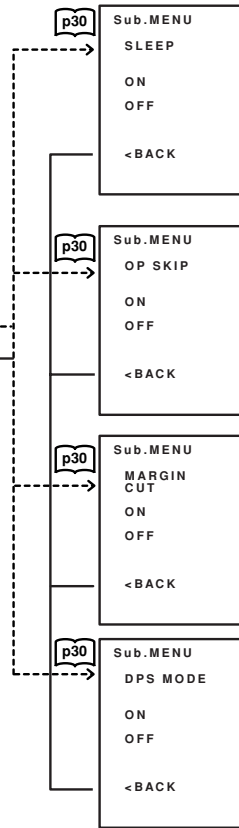



MENU ITEMS

The MENU is used to set the following items. The settings can be saved or changed by pressing SET button.

WB	Adjusts white balance.
COLOR	Adjusts color of the print image.
SHARP	Adjusts image outline.
LCD	Adjusts color and brightness of the LCD
CAPTURE MODE	Sets flash and shows the settings made by an installer.
MODE	Sets resolution of an image.
TRIM	Sets the printing area of an image.
S.MENU	Opens the sub menu.
RESET	Resets the above items to the settings made by an installer.
< EXIT	Exits this menu.

OPERATING MENU

Use the buttons on the camera to display MENU and select and set functions.

- 1 Press **CAMERA/PLAY** button to switch the camera to **CAMERA mode**.

In CAMERA mode,  mark is displayed on the upper right of the LCD.

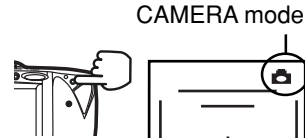

- 2 Press **SET** button for more than 3 seconds. MENU is displayed.

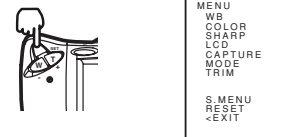

- 3 Select the desired item by pressing **T (+)** or **W (-)** button. In the right figure, COLOR is selected.



- 4 Press **SET** button to open the item. When you select S.MENU, see page 30.



- 5 Press **T (+)** or **W (-)** button to select the sub item. In the right figure, "a" is selected.





6 Press SET button.
The item "a" opens.



```
COL -a
R   : 0
B   : 0
HUE : 0
STEP : 0
TEST
PRINT
<-BACK
```

7 Press T (+) or W (-) button to select an item.



```
COL -a
R   : 0
B   : 4
HUE : 0
STEP : 0
TEST
PRINT
<-BACK
```

8 Press SET button.
"R" is selected. The value being changed blinks.



```
COL -a
R   : 2
B   : 0
HUE : 0
STEP : 0
TEST
PRINT
<-BACK
```

9 Press T (+) or W (-) button to change setting.



10 Press SET button.
The changed value is saved. Blinking stops.



```
COLOR :
a
b
c
<-BACK
```

11 Repeat the above steps 7 to 10 to change other values.

12 Select <BACK by pressing T (+) or W (-) button, then press SET button.
MENU is displayed.



```
MENU
WB
COLOR
SHARP
LCD
CAPTURE
MODE
TRIM
S MENU
RESET
<-EXIT
```



13 Select <EXIT and press SET button to go back to CAMERA mode.
If you wish to reset the settings, select RESET. Then select YES and press SET button.



```
4 D a n
```



WB

This menu is used to adjust white balance of the camera.

LEVEL Sets the color temperature. When the value is lower, the color becomes reddish. When the value is higher, the color becomes bluish.

4000K
4400K
4800K
5200K
5600K
5800K
6000K
6200K
6600K
7000K

WB
LEVEL
MANUAL
LOCK
<BACK

MANUAL Sets the color level manually.

R Adjusts the level of red color.
B Adjusts the level of blue color.

LOCK

IN Adjusts white balance based on the most recent white chart image.

RECALL Set the value to the setting locked before.

COLOR

Sets the color of the print image. You can save 3 kinds of settings (a, b and c).

When selecting any one, the settings are displayed.

R Adjusts the red color of print image.

B Adjusts the blue color of print image.

HUE Adjusts the color tint.

STEP Sets the variation of R, B and HUE.

TEST PRINT Performs self test print. The images are printed with the setting data.

- Use TEST PRINT to find the best settings by changing the values of the image (which is taken most recently).

(Print sample)

R : +3 B : 0 Hue : +2	R : +3 B : -1 Hue : +2	R : +3 B : -2 Hue : +2
R : +2 B : 0 Hue : +2	R : +2 B : -1 Hue : +2	R : +2 B : -2 Hue : +2
R : +1 B : 0 Hue : +2	R : +1 B : -1 Hue : +2	R : +1 B : -2 Hue : +2

Absolute value

R : +1 B : +1 Hue : 0	R : +1 B : 0 Hue : 0	R : +1 B : -1 Hue : 0
R : 0 B : +1 Hue : +0	R : 0 B : 0 Hue : 0	R : 0 B : -1 Hue : 0
R : -1 B : +1 Hue : 0	R : -1 B : 0 Hue : 0	R : -1 B : -1 Hue : 0

Relative value (when STEP is 1)

COLOR :
a
b
c
<BACK

B / W :
a
b
c
<BACK



When LCD is on B/W mode, the following items are displayed.

- Y Adjusts the yellow color of print image.
- M Adjusts the magenta color of print image.
- C Adjusts the cyan color of print image.
 - Test print is not available on B/W mode and when using with a Compact Flash.

```
COL -a
R   : 0
B   : 0
HUE : 0
STEP : 0
TEST
PRINT
<BACK
```

```
B / W -a
Y   : 0
M   : 0
C   : 0
<BACK
```

SHARP

Adjusts the sharpness of the image.

- SOFT Softens the image sharpness.
- NORMAL Does not adjust the sharpness.
- HARD Reinforces the sharpness.
- USER Adjusts the sharpness voluntarily.
 - Coef Sets the strength of sharpness.
 - Offs Sets offset value. When the value is increased, the sharpness is reinforced.

```
SHARP :
SOFT
NORMAL
HARD
USER
<BACK
```

LCD

Adjusts the image quality on the LCD.

- COL. Sets color depth of the LCD.
- BRIGHT Sets brightness of the LCD.

```
LCD :
COL.
BRIGHT
<BACK
```

CAPTURE

Selects the conditions for taking pictures and adjusts brightness.

- FLASH Selects whether flash is available or not.
 - ON Triggers the flash when taking a picture.
 - OFF Does not trigger the flash.
- EXP. CENTER Adjusts the light intensity from strobe flashing to image capturing.
 - Increase the value to get a brighter image and decrease to get a darker image.
 - Before changing this value, make sure to set EXP. value to 0. To check the EXP., go back to the CAMERA mode and press EV button.

```
CAPTURE :
FLASH :
ON
OFF
EXP.CENTER
+290
IRIS
F2.8
<BACK
```

```
CAPTURE :
FLASH :
ON
OFF
ST.
1 / 125
IRIS
F2.8
<BACK
```

- IRIS Selects iris setting.

When FLASH is set to OFF, the following items are displayed.

- ST. Selects shutter speed.
- IRIS Selects iris setting.



MODE

Selects the resolution.

- <1.6m HS When the distance between the camera and the object is less than 1.6m, the resolution sent to the printer becomes 800*600 pixels in case of 1 and 2-multi prints. The printing speeds becomes faster.
- <1.6m HQ When the distance between the camera and the object is less than 1.6m, the resolution sent to the printer becomes as follows. The image quality becomes better. MULTI is set to 1 or 2 : Data of 1280*960 pixels is sent. MULTI is set to 4 to16 : Data of 640*480 pixels is sent.
- >1.6m When the distance between the camera and the object is more than 1.6m, the resolution sent to the printer becomes 640*480 pixels.
 - This item is available when selecting MULTI : 4 to 16.
- L.SIZE The resolution sent to the printer becomes 1600*1200 pixels.
 - This item is available when selecting MULTI : 1L.

```

MODE :
<1.6m  H S
        H Q
>1.6m
L-size
<BACK
  
```

Picture elements transferred to printer

- : Not selectable

MODE	Shooting resolution	Print layout							
		1L	1	2	4	4D	6	16	
1	L-SIZE	1600x1200	1600x1200	-	-	-	-	-	-
	<1.6m HS	1280x960	-	800x600	800x600	640x480	640x480	640x480	640x480
	<1.6m HQ	1280x960	-	1280x960	1280x960	640x480	640x480	640x480	640x480
2	>1.6m	640x480	-	640x480	640x480	640x480	640x480	640x480	640x480

TRIM

Multi Selects multi print mode.

- 1L 1-image on a sheet
- 1 1-image on a sheet
- 2 2-image on a sheet
- 4 4-image on a sheet
- 4D 4-image on a sheet (2 pictures of 2 different images)
- 6 6-image on a sheet
- 16 16-image on a sheet

```

TRIM
MULTI
1L
1
2
4
4D
6
16
<BACK

TRIM
MULTI2
USER
L : 0
R : 0
T : 0
B : 0
<BACK
  
```

(when 2 is selected)

After selecting the multi mode and pressing SET button, the following item is displayed.

In this item, adjust the print size of each section of the print layout. Each value shows the amount of trimming from the maximum value.



- USER Sets the print area of the image.
 L Sets the print area of the left side.
 R Sets the print area of the right side.
 T Sets the print area of the top side.
 B Sets the print area of the bottom side.

Multi	Maximum print size (mm approx.)	Setting at factory shipping				Print size (mm approx.)	Resolution (pixels)
		T	B	L	R		
1L	93.5x124.7	0	0	0	0	93.5x124.7	1600x1200
1	99.8x74.8	0	0	0	0	99.8x74.8	1280x960
2	51.0x74.8 (S) 51.0x65.0 (L)	4	8	0	0	51.0x73.9	654x948
4, 4D	49.9x37.4	8	16	6	6	48.0x36.5	616x468
6	32.8x37.4	10	20	18	18	29.9x35.0	384x450
16	24.9x18.7	0	0	0	0	24.9x18.7	320x240

■ **Multiple prints with L size ink sheet**

If you print multiple images with L size ink sheet, the images are printed as follows.

- 1 1-image (75x100mm) 2 4-image (50.8x74mm)
 4,4D 6-image (36.5x48mm) 6 9-image (30x35mm)
 16 24-image (19x25mm)

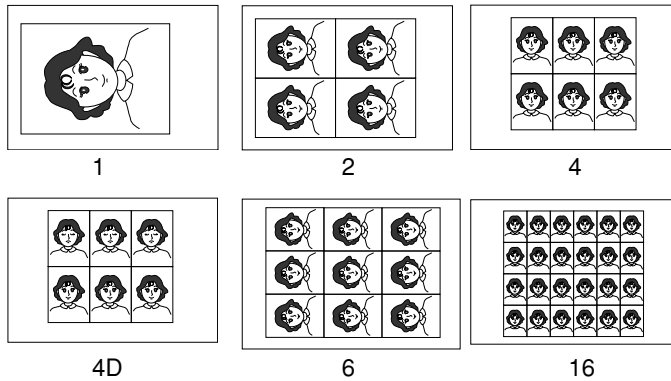

S.MENU (Sub.MENU)

See the next page for details.

RESET

- YES All settings in MENU are reset to the settings made by the installer.
 NO Reset is not performed.

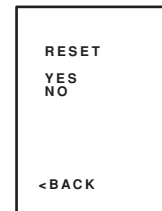
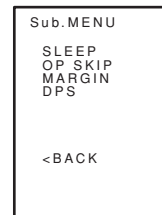



SUB MENU

- SLEEP** Selects whether the LCD is turned off or not when any camera operation is not carried out for more than 5 minutes.
- ON LCD is turned off when any camera operation is not carried out for more than 5 minutes. Press SET button to be active the camera.
 - OFF LCD is not turned off.
- OP SKIP** Selects whether the overcoating process on the print is skipped or not.
- ON Overcoating process is skipped.
 - OFF Overcoating process is carried out.
- MARGIN CUT** Selects whether the margin of the printed paper is cut or not.
- ON Margin is cut.
 - OFF Margin is not cut.
- DPS**
- ON When you connect this system with DPS Click, select ON.
 - OFF When you do not connect this system with DPS Click, select OFF.

Sub.MENU

SLEEP
OP SKIP
MARGIN
DPS

<BACK

CONNECTING WITH DPS SYSTEM

This camera can be connected with DPS Click system by equipping AC adapter (option) as a power supply.

CHECKING TOTAL NUMBER OF PRINTS

- 1 In camera mode, press **CAMERA/PLAY** button for 3 seconds.
- 2 The total number of prints is displayed.
- 3 Press **SET** or **CAMERA/PLAY** button to return to the operation mode.

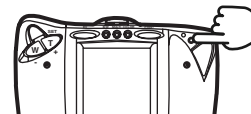

NOTE

When DPS mode is ON, this function is not active.

PRINTS
TOTAL
3000
REMAIN
111
<BACK



OPTIMUM SETUP FOR THIS SYSTEM

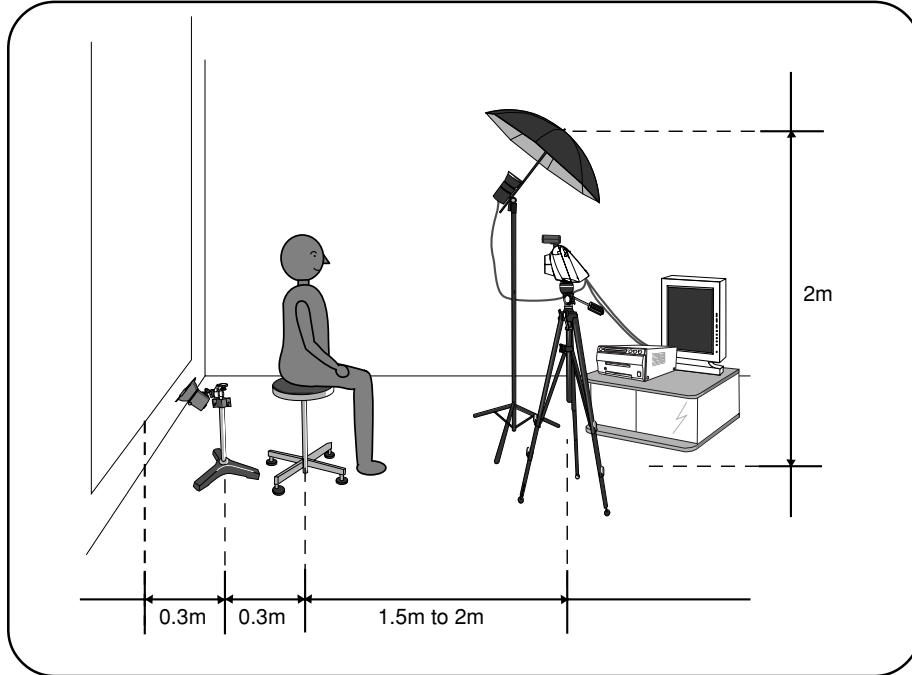

■ EFFECT OF BACK FLASH

- The back flash reduces the shadow behind the subject.

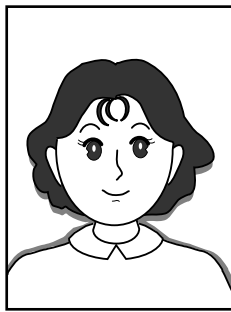

Without back flash

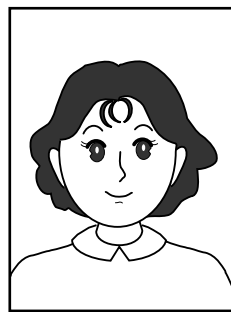

With back flash



9. TROUBLESHOOTING

ERROR MESSAGES AND COUNTERMEASURES

If for some reason printing is not possible or error occurs during printing, the error message will appear on the LCD of the camera and the monitor.

In this case, follow the procedure described below.

Error messages	Causes	Countermeasures
Paper jam	Paper jam occurs.	Remove the jammed paper. Re-install the print paper and ink sheet and press the FEED&CUT button.
No ink cassette	Ink sheet cartridge is not installed.	Install the ink sheet cartridge. Or re-install the ink sheet cartridge.
Change ink	Ink sheet ends.	Replace the ink sheet and paper with a new one.
Check ink	Ink sheet information can not be detected.	Re-install the ink sheet cartridge. Or set the IC chip correctly. If the status is not improved, replace the ink sheet and paper.
	Unusable ink sheet is installed.	Turn off the power and then turn on, and check the status. If the status is not improved, replace the ink sheet and paper.
	Remaining counter in the IC chip is 0.	Re-install the ink sheet cartridge. Or set the IC chip correctly. If the status is not improved, replace the ink sheet and paper.
Paper and ink not match	Combination of ink sheet and paper is wrong.	Check the combination of ink sheet and paper. If the status is not improved, replace them with a new set.
No paper found	Print paper is not installed.	Set a new roll of paper. Or re-install the paper.
Change paper	Paper end hole is detected.	Set a new roll of paper.
Door open	Door is open.	Close the door.
Hardware problem	Mechanism cannot initialize its position.	Mechanical error. If possible, press FEED&CUT button to feed and cut the paper.
	Being initializing mechanism.	Wait until paper feed and cut operation.
Printer not found	The power is off or a cable is not connected.	Turn on the power or connect the cable.
	A cable is disconnected or the power is turned off during data transfer.	Connect the cable.



Error messages	Causes	Countermeasures
Printer busy	Any button is pressed during data transfer.	Wait until the printing is completed.
No image for this MODE	The PRINT button is pressed when no picture data is stored in the memory position.	Take a picture to store it in the memory.
Printer not found	The power is off or a cable is not connected.	Turn on the power or connect the cable.
Unknown printer	A printer other than CP900DW(ID) is connected.	Connect with CP900DW(ID).
Please turn off the power then turn on with CF card	The Compact Flash is pulled out when the power is turned on.	Turn off the power and insert the Compact Flash. Then, turn on the power again.
DPS not found	When DPS mode, no USB cable is connected or the PC is not running.	Connect the USB cable or start up the PC and start an application software.
Ink type	S-size ink sheet is installed when L-mode is selected in the menu.	Change to the L-size ink sheet.
Unusable format card	Initial process for CF card insertion. The format of the card is not suitable.	Format the Compact Flash by FAT12 or 16.
Access problem 1 - 8, 20	Errors concerning the Compact Flash	Replace the Compact Flash.
Data full 1 - 3	Errors concerning the Compact Flash	Replace the Compact Flash.



BEFORE CALLING FOR SERVICE

Use the following troubleshooting chart to resolve any apparent defect in operation. If you are unable to resolve the problem, unplug the power cord and contact your dealer.

Causes	Countermeasures
No power	<ul style="list-style-type: none"> • Is the power cord plug disconnected from the outlet? Connect the power cord plug to the outlet firmly. • Is the printer turned on? Confirm that the printer is turned on.
No signal	<ul style="list-style-type: none"> • Is the cable connected correctly? Check each connection.
Image is not printed.	<ul style="list-style-type: none"> • Is the image data sent to the printer? Confirm that the image data is sent to the printer. • Is the print paper or ink sheet used up? Check the status. • Is the printing unit of the printer set correctly? Set the printing unit correctly.
The camera setting does not work.	<ul style="list-style-type: none"> • Is the camera connected to the printer? Check the connection.



10. SPECIFICATIONS

Camera		Printer	
Image pickup device	1/2.7 type CCD	Printing method	Sublimation Dye thermal
No. of effective pixels	1636H x 1236V (2,022,096 pixels)		3 colour faces progressive printing (yellow, magenta and cyan)
Video signal	PAL colour system	Print quality	Dot resolution max.1676x1280dots
Digital signal	Data format Y, C (JPEG) / RGB		Number of grades 256 for each color
	Data size 1600x1200/1280x960/640x480 pixels	Printing time	Approx. 46sec./sheet (S size one image print)
	Interface USB Ver. 1.1	Ink sheet	Special cartridge method
Function	lens control (zooming, focusing), Exposure, Color, White balance, Sharpness, Flash control, Shooting, Data transfer	Print paper	Special roll paper L size 162x110mm Printing area 130x100mm Special roll paper S size 100x105mm Printing area Wide mode 100x75mm
Lens	Focal length 5.8mm - 17.4mm (Equivalent 35mm film 38mm - 115mm) Maximum Aperture Ratio F2.8/F5.6 (at widest angle) Object Distance 80cm - ∞	Supply method	Automatic
Temperature	Operating 0°C to 40°C Safekeeping -20°C to +60°C	Interface	USB Ver. 1.1
Current consumption	DC12V 1A	Power supply	AC 120V, 50/60Hz AC 220-240V, 50/60Hz
External dimensions	188mm(W) x 143mm(H) x 173mm(D) (excluding external connectors)	Power consumption	1.4A(AC 100-120V, 50/60Hz) during printing (0.2A when not printing) 0.7A(AC 220-240V, 50/60Hz) during printing (0.1A when not printing)
Weight	Approx. 1.2 kg	Installation conditions	Temperature 5°C to 40°C Humidity 20 to 80% (no dewing)
LCD	4 inch	Operation altitude	Horizontal ± 5°
Accessories	Operation Manual Power and USB cable	External dimensions	280mm(W)x150mm(H)x400mm(D)
		Weight	11kg
		Accessories	Operation Manual Printer driver Ink-cassette Power cord Spacers Screws

• Specifications are subject to change without notice.

SLD Security & Communications
The Old Forge, Ockham Lane, Ockham, Surrey GU23 6PH England
Phone +44.1483225633 · Fax +44.1483225634
sales@sld.co.uk · www.sld.co.uk

